

Model 2102 or 2102-I⁽¹⁾ Power Tool

Introduction

The Model 2102 or 2102-I power tool consists of a grinding drum centrally located between a set of four mandrel and is a 50 cycle, 240 volt unit. The tool is capable of tapering 2" - 4" RED THREAD® II and RED THREAD IIA pipe and scarfing 3" RED THREAD II and RED THREAD IIA pipe. The tapering and scarfing angle is factory set. To compensate for wear of the grinding drum, NOV Fiber Glass Systems provides a thickness adjustment .

Warning: Use caution when operating this tool. Hold pipe firmly. Do not allow machine to turn pipe. Check mandrels often to make sure they are properly tightened.

To Taper

1. Cut pipe ends square ($\pm 1/8"$), and set up tool in either the horizontal or the vertical position.
2. Turn motor on. Allow a few seconds until the motor reaches speed.
3. Slowly insert the pipe onto the mandrel, making sure alignment is as even as possible. Rotate in a counter-clockwise direction until the end of the pipe rests against the back plate. Do not turn the pipe too quickly, as this can stall the motor. If the motor starts to bog down, slow your rotation and insertion, but do not stop. The sound of the motor will indicate whether the motor is bogging down. Keep turning until the pipe is making minimum contact with the grinding drum. Make two to three complete revolutions and retract pipe from the tool while continuing to rotate pipe. Turn motor off.

4. If the grinding drum locks up on the pipe, turn the motor off immediately and try to wiggle the pipe loose. If this doesn't work, cut the pipe off as near the mandrel as possible, loosen the mandrel (allen head bolt inside of mandrel), remove pipe, and retighten the mandrel.
5. Occasionally check the tapered pipe by inserting a field-made spigot into the bell of a factory fitting, and compare the insertion with the insertion of a factory spigot into the same bell. Insertion tolerance for the field-made spigot is $\pm 1/8"$. **Note:** When using a pipe with T.A.B.™ threads for comparison, recognize that factory spigots with T.A.B. threads typically insert $1/4"$ less than factory spigots without T.A.B. threads.

To Scarf

1. Follow steps 1 through 4 from To Taper Section.
2. Occasionally check the machined pipe by inserting the scarfed pipe end into a secondary containment two-piece fitting. Close down around the pipe end and check the fit of the pipe/fitting joint. The pipe should fit snugly, and the flanges of each containment fitting should mate flush with no apparent gaps (see Fig. 1.0).

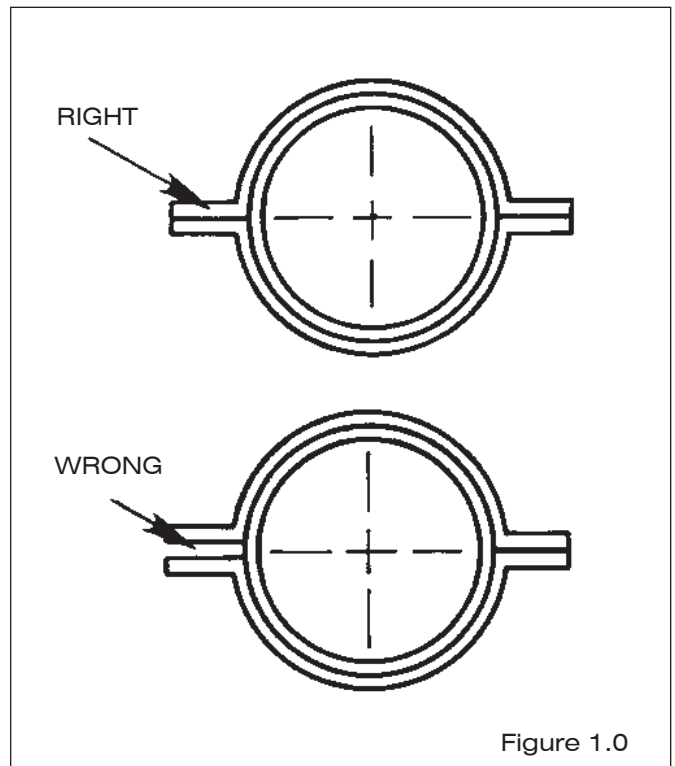
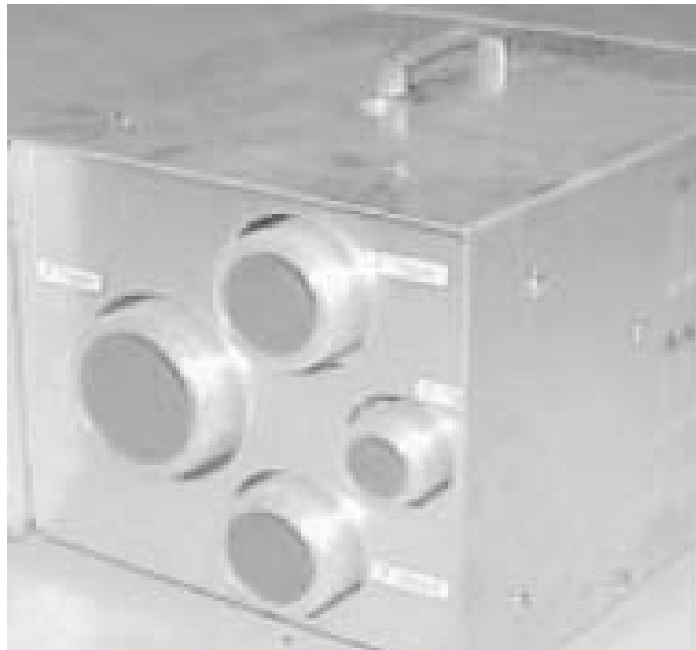

Figure 1.0

www.fgspipe.com

2700 West 65th Street
Little Rock, Arkansas 72209
Phone: 1 (501) 568-4010

25 S. Main Street
Sand Springs, Oklahoma 74063
1 (918) 245-6651

NOV Fiber Glass Systems

To Adjust Thickness

1. Loosen the allen head bolt located in the center of the hollowed out mandrel.
2. Adjust machined thickness as follows:
 - a. Rotate mandrel line away from reference line to increase thickness, i.e. to make thicker (see Fig. 2.0).

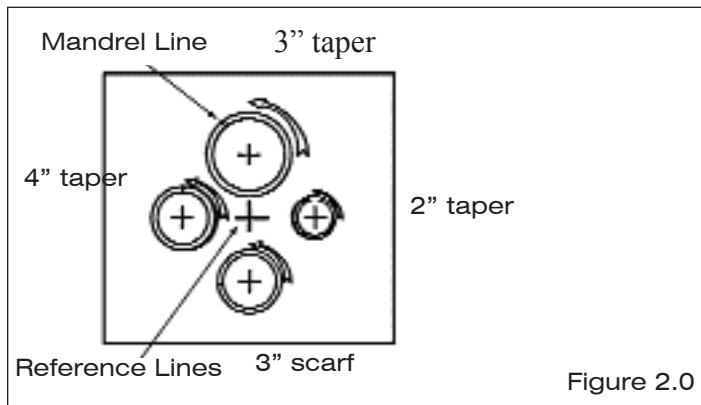

- b. Rotate mandrel line towards reference line to decrease thickness, i.e. to make thinner.
- c. Tighten the allen head bolt securely

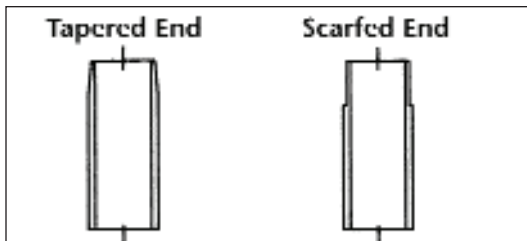

National Oilwell Varco has produced this brochure for general information only, and it is not intended for design purposes. Although every effort has been made to maintain the accuracy and reliability of its contents, National Oilwell Varco in no way assumes responsibility for liability for any loss, damage or injury resulting from the use of information and data herein nor is any warranty expressed or implied. Always cross-reference the bulletin date with the most current version listed at the website noted in this literature.

PRODUCT FEATURES AND BENEFITS

- Weighs approximately 50 lbs.
- Electrically powered.
- Tapers 2" - 4" pipe in just 10 seconds.
- Scarfs 3" pipe in 20 seconds.
- No loose blades, blade holders, or mandrels
- Specially designed for tapering and scarfing RED THREAD IIA piping.

www.fgspipe.com

2700 West 65th Street
Little Rock, Arkansas 72209
Phone: 1 (501) 468-4010

25 S. Main Street
Sand Springs, Oklahoma 74063
1 (918) 245-6651

NOV Fiber Glass Systems

©2009, NATIONAL OILWELL VARCO
®Trademark of NATIONAL OILWELL VARCO
F6624 February 2009