

# 8" Tapering Tool Assembly & Operating Instructions

When cutting fiberglass pipe, the cut end must be tapered before bonding to a fitting or other pipe. This tool was designed to cut a one (1) degree taper on 8" diameter pipe. Refer to **Manual No. F6000** for complete installation instructions.

## Setting The Tool For The Proper Taper

1. Clamp pipe that has been tapered at the factory into position. To prevent damage to the pipe, protect it from metal surfaces with two 180 degree sections of the same size pipe. (See Fig. 1.) If possible, clamp the pipe at least two feet from the end of the pipe so it doesn't oval.

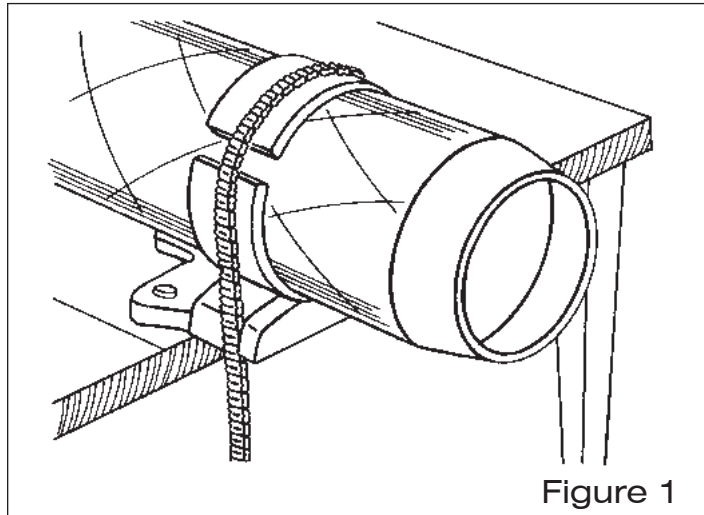

Figure 1

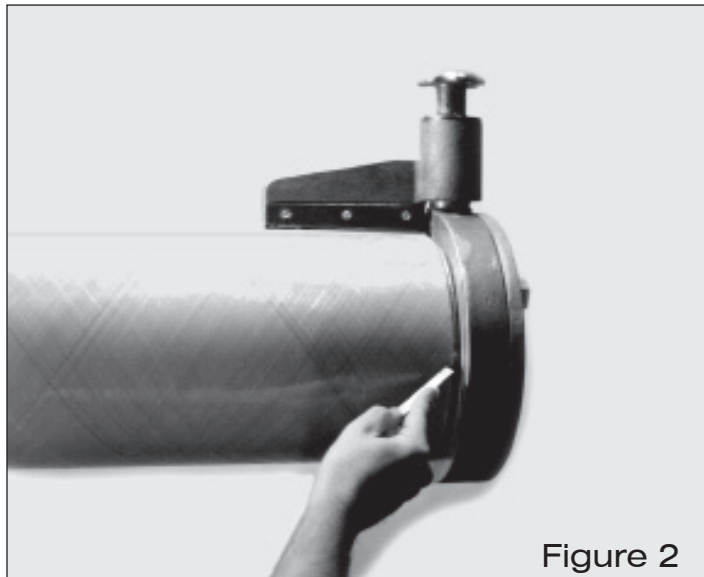

Figure 2

2. Insert the tool into a piece of pipe with a factory taper. The small shoulder on the mandrel should be against the end of the pipe. (See Fig. 2.)

3. Expand the mandrel expansion bolt in the back center of the tapering tool. This should be tightened only enough to prevent the mandrel from rotating inside the pipe. **DO NOT OVERTIGHTEN.**

4. Mount the blade holder with the three bolts with washers, but do not tighten, yet. (See Fig. 3.)

5. The blade holder should be at the bottom point of rotation to insert and adjust the blade.

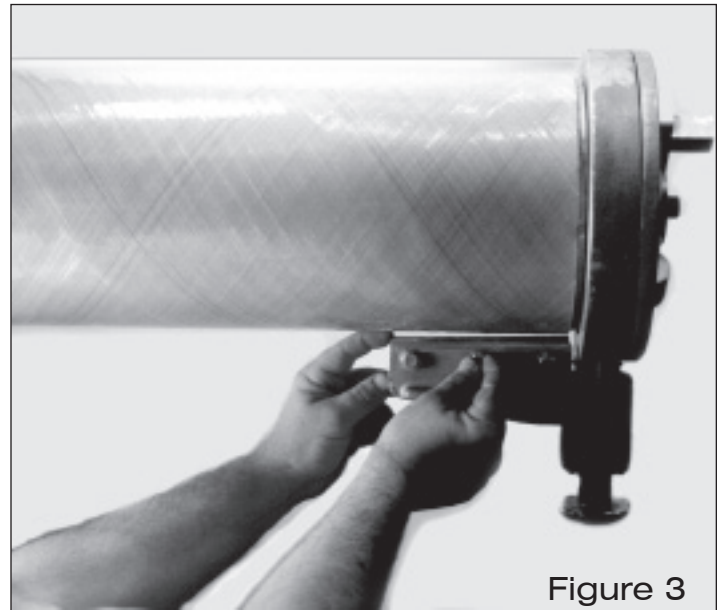

Figure 3

6. Insert the blade with the wide side of the blade facing the blade holder. The blade fits into the slot and should extend past the end of the pipe, but should not touch the tool body.

7. Be sure the blade is resting properly in the slot.

8. Tighten the three bolts to secure the blade.

9. Rotate the cutting head 180 degrees until it is at the top of rotation.

10. Tighten the cutting head feed knob until the blade makes light, uniform contact with the factory taper. If the blade does not make uniform contact, check the blade setting. (See Fig. 4.)

11. Adjust the depth stop bolt (on the cutting head) to make contact with the tool body. Tighten the jam nut. The tool should now be set to cut the proper taper depth and angle.

12. Back off the cutting head feed knob until the blade clears the pipe.

13. Loosen the mandrel expansion bolt.

14. The tool should now be set for proper tapering and may be removed from factory tapered pipe end.

[www.fgspipe.com](http://www.fgspipe.com)

2700 West 65th Street  
Little Rock, Arkansas 72209  
Phone: 1 (501) 568-4010

25 S. Main Street  
Sand Springs, Oklahoma 74063  
1 (918) 245-6651

**NOV** Fiber Glass Systems

Figure 4

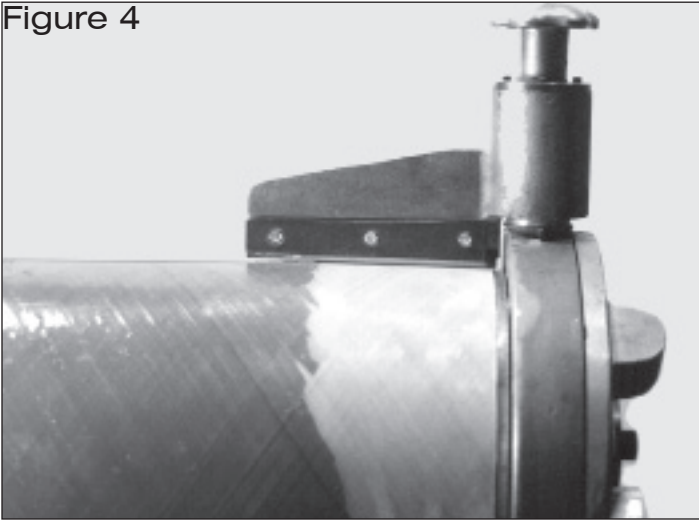

### Making Field Tapers On Untapered Pipe

15. Clamp the pipe to be tapered into position. Protect it with two 180 degree sections of the same size pipe to prevent damage to the pipe. If possible, clamp the pipe at least two feet away from the pipe end so it doesn't oval.

16. Insert the tool that has been pre-set into the pipe end to be tapered. The small shoulder on the mandrel should butt against the end of the pipe.

17. Make sure the blade is not touching the pipe.

18. A power source may now be connected to the  $1\frac{5}{16}$ -inch square shaft. The crank handle provided in the tool may be used for manual power. (See Fig. 5.)

19. Check for high spots on the pipe by making one complete revolution of the tool with the blade at least  $\frac{1}{4}$ " from the surface of the pipe.

20. All tapering must be done with the cutting head moving counterclockwise as you face the pipe. (See Fig. 5.)

21. Begin cutting very slowly while the tool is rotating by turning the cutting head feed knob. Allow at least one revolution between adjustments to prevent overloading of tool at high spots on the pipe.

22. Once the blade is cutting a full 360 degrees, you may increase the cutting speed. **DO NOT FORCE CUT.**

**Note:** If tapering operation has to be stopped for any reason, back off the cutting head feed knob to relieve pressure from the blade.

Continue tapering until the depth stop bolt touches the tool body. When the depth stop bolt touches the tool body, continue rotating the tool for two or three revolutions to ensure proper clean up.

23. After the taper has been cut, back off the blade while the tool is still rotating. Remove the tool by backing off the mandrel expansion bolt on the center of the tapering tool. Loosen the bolt only enough to remove the tool. Do not remove the bolt.

Figure 5

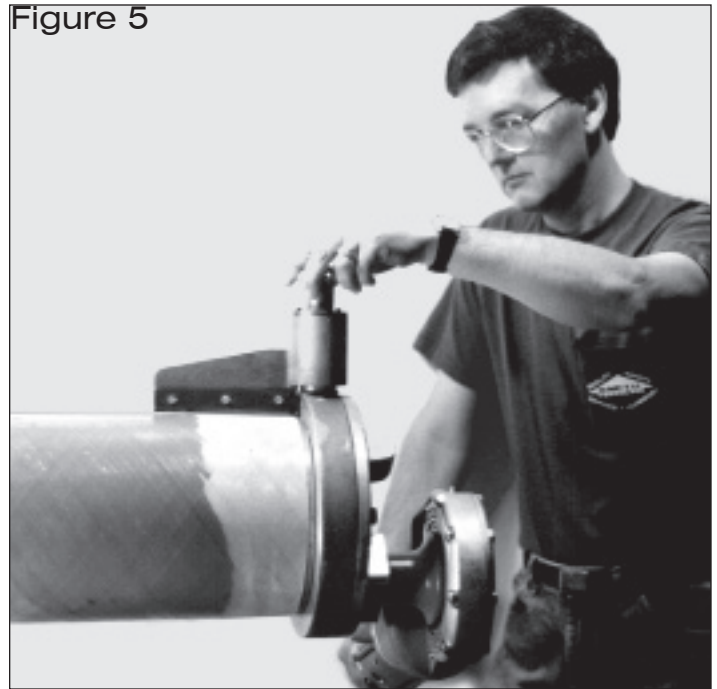

24. Compare the field taper to the factory taper used to set the tool. Use a factory bell as a gauge (a sleeve coupling works best). Use the same bell to check the factory taper and field taper. (See Fig. 6.)

25. Slide the bell on the factory taper that was used to set the tool and tap on lightly. Be sure the taper is seated properly.

26. Mark the inside of the bell at the end of the pipe. Mark all the way around the end to check for "cocking" of the spigot. If it is impossible to reach into the bell, mark the outside diameter (O.D.) of the spigot end. Then, remove the spigot and measure the insertion length at the longest point. (See Fig. 8.)

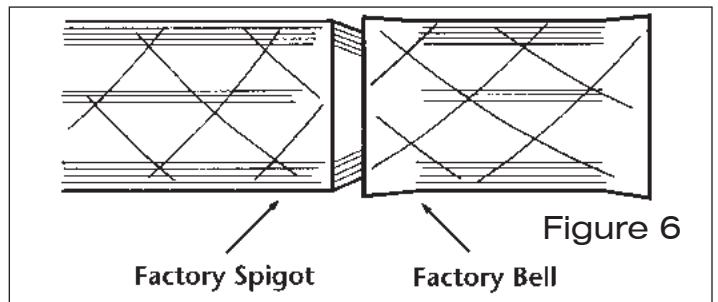

27. If it is difficult to separate this joint, lightly tap straight down on the joint with a 2x4 or a rubber hammer. Do not use a metal hammer.

28. Slide the same bell onto the field taper; tap on lightly. Be sure the taper is seated properly.

29. Inspect the end of the pipe inside the bell. A gap all the way around the circumference indicates that the taper is too steep and not acceptable. Recheck the blade setting.

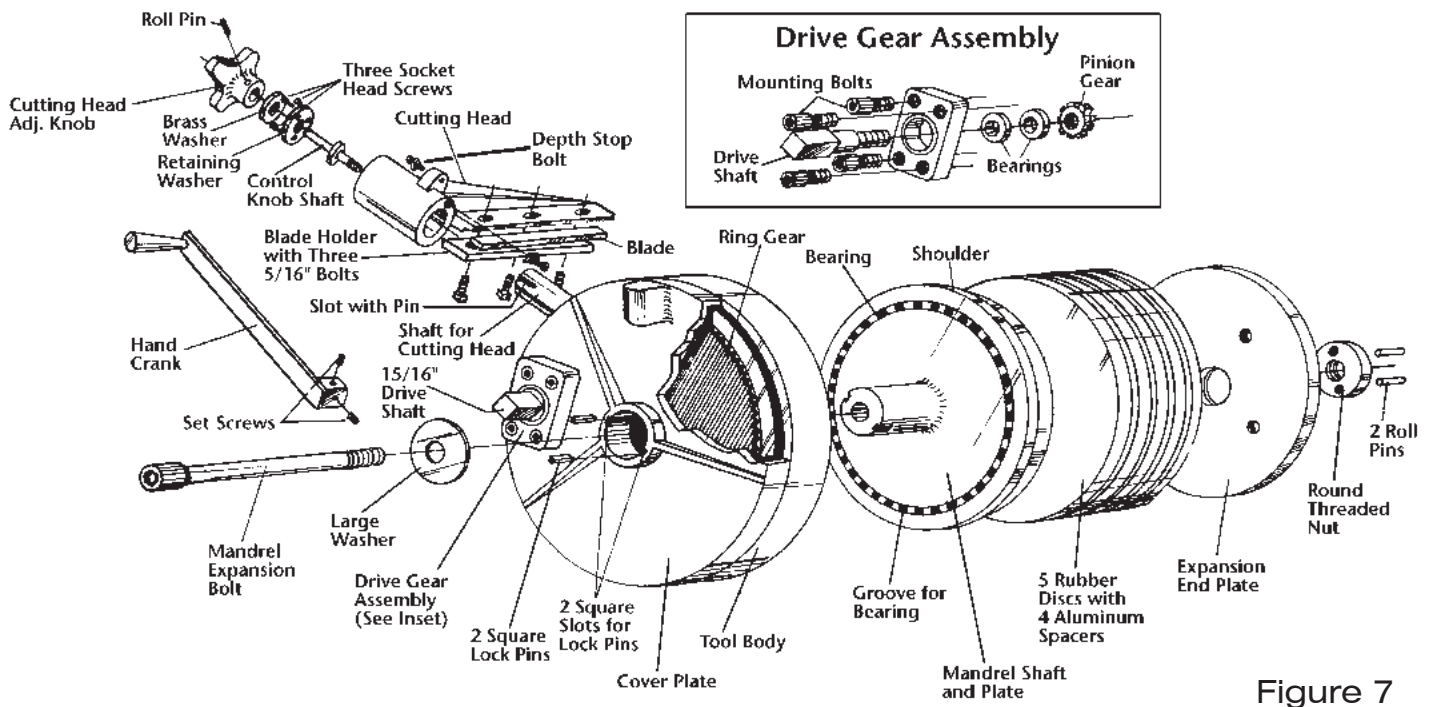
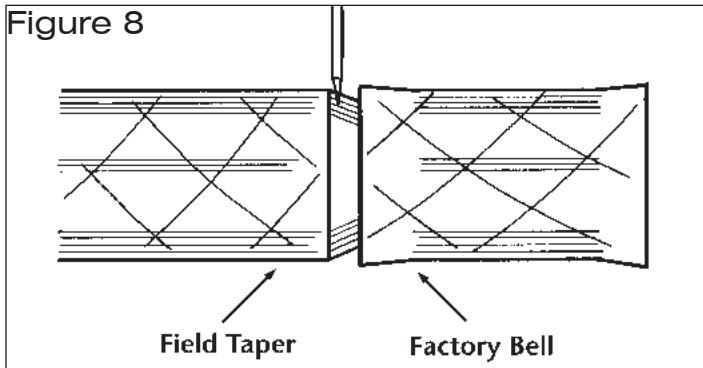

Figure 7



30. Mark the inside of the bell at the end of the pipe. (See Fig. 9.) If it is impossible to reach into the bell, mark the O.D. of the spigot end, then remove the spigot end and measure the insertion length at the longest point.

31. Compare the insertion length of the factory taper to the field taper. If the two insertion lengths are within  $\frac{1}{8}$ " of each other, the depth stop is set correctly. If the difference is greater than  $\frac{1}{8}$ " the depth stop must be readjusted.

32. If the insertion depth is correct and the taper angle check is good, the tool is set for tapering.

### Tapering Short Nipples

33. Weld a length of 2" steel pipe to a 2" 150 lb. steel flange. Bolt the steel flange to the expansion end plate (four threaded holes in end plate). The nipple to be tapered should be put over the steel pipe and onto the mandrel. Clamp the steel pipe in the vise. The steel pipe holds the mandrel, and the mandrel will hold the pipe for tapering. (See Fig. 10.) Set up the tapering tool as shown in Fig. 10 and follow steps 15 through 32.

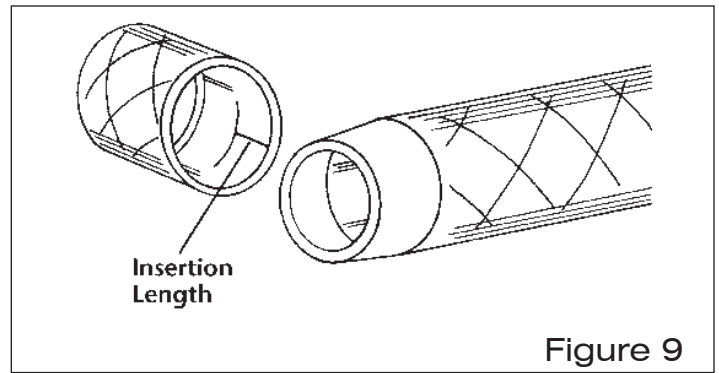

Figure 9

### Field Stripping The Machine

34. Remove  $\frac{1}{2}$ " mandrel expansion bolt and large washer from cover plate.

35. Remove drive gear assembly by removing the four socket head cap screws.

36. Remove drive gear assembly with gear and shaft intact. (The gear may be removed from the shaft by unscrewing LEFT HAND THREADS.)

37. If the shaft must be replaced, it can be pressed or driven from the bearings.

38. Remove cover plate from the tool body by tapping carefully with a plastic hammer. It may be necessary to strike the end of the shaft sharply with a plastic hammer. (DO NOT USE A STEEL HAMMER AS IT WILL MAR THE SHAFT END.)

39. To remove the ring gear from the tool body, tap out the four retaining pins with a drive punch.

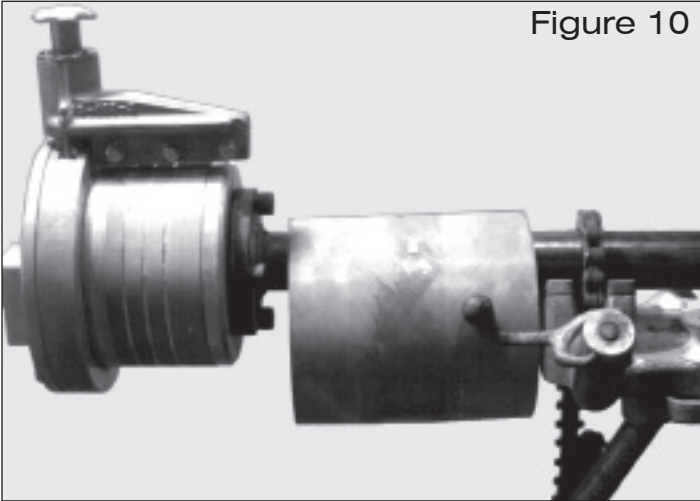

Figure 10

40. A new ring gear may be installed at this time if necessary.  
**Note:** Each tool is drilled individually, thus EACH NEW RING GEAR MUST BE DRILLED TO FIT YOUR PARTICULAR TOOL.

41. Unscrew the cutting head at the feed knob until the entire cutting head assembly separates from the tool body, then slide the retaining dowel pin out of the keyway.

42. Remove three socket head screws from the cutting head assembly which holds the cutting head feed shaft to the cutting head.

43. To remove the cutting head feed knob from the shaft, drive out the roll pin with the drive punch. Knob and retaining washer will slip off the end of the shaft.

44. Remove the expansion end plate from the end of the mandrel assembly.

45. Carefully remove rubber discs and aluminum spacers by sliding off end of mandrel shaft and plate.

#### Reassembling Machine

46. Replace rubber discs and aluminum spacers by sliding onto mandrel shaft and plate.

47. Replace expansion end plate.

48. Reassemble cover plate and tool body by sliding the cover plate over the mandrel shaft and plate, aligning the keyways in the shaft and cover plate.

49. Tap two locking keys into the keyways.

50. Replace the large washer on the face of the cover plate.

51. Replace the mandrel expansion bolt.

52. Reassemble the cutting head feed shaft, retaining washer, and knob

53. Replace the cutting head feed shaft assembly on the cutting head with three socket head screws.

54. Replace the cutting head assembly on the tool, making sure that the dowel pin is in the slot and that slots are aligned while engaging threads on the cutting head feed shaft.

55. Take several turns on the cutting head feed knob so the dowel pin will be retained.

56. Reassemble drive gear assembly with shaft and gear. (LEFT HAND THREADS.)

57. Replace the drive gear assembly on the cover plate with four socket head cap screws.

58. The tool is now ready to be set to a factory taper.

#### Maintenance Hints For 8" Tool

59. To improve mandrel expansion, use a lubricating powder such as graphite between each of the rubber discs and the aluminum spacers.

60. Do not overtighten the mandrel expansion bolt to compensate for tool slippage. Overtightening will strip or break the mandrel expansion bolt.

61. Feed the cutting head and blade slowly. DO NOT FORCE CUT. Rapid feeding will strip the drive gear and/or the ring gear (especially when using a power drive). A slow, uniform feeding rate will yield a more accurate taper.

62. Use a multipurpose grease on the ring and drive gears when tool has been in use for a long period of time.

63. Replace the flat washers on the blade holder bolts if they are missing.

National Oilwell Varco has produced this brochure for general information only, and it is not intended for design purposes. Although every effort has been made to maintain the accuracy and reliability of its contents, National Oilwell Varco in no way assumes responsibility for liability for any loss, damage or injury resulting from the use of information and data herein nor is any warranty expressed or implied. Always cross-reference the bulletin date with the most current version listed at the web site noted in this literature.

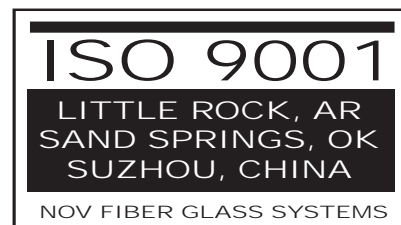

[www.fgspipe.com](http://www.fgspipe.com)

2700 West 65th Street  
 Little Rock, Arkansas 72209  
 Phone: 1 (501) 468-4010

25 S. Main Street  
 Sand Springs, Oklahoma 74063  
 1 (918) 245-6651

**NOV Fiber Glass Systems**

© 2009, NATIONAL OILWELL VARCO  
 ® Trademark of NATIONAL OILWELL VARCO  
 F6608 February 2009